

PARTICLES, NEUTRINO AND PHOTONS IN THE MAGNETOSPHERE OF A COLLAPSING STAR

V.G. Kryvdyk

Faculty of Physics, Taras Shevchenko National University of Kyiv
64/13, Volodymyrska Street, 01601, Kyiv, Ukraine
kryvdyk@gmail.com

ABSTRACT. The formation of the stellar magnetosphere during the gravitational collapse is discussed. Primary protons and electrons accelerate in the star's magnetosphere during its gravitational collapse. In what follows, the flux of particles, photons and neutrinos generated in the magnetosphere is multiplied in a cascade process initiated by the self-interaction of particles and their interaction with magnetic fields. These processes are especially effective for the formation of magnetospheres in collapsing stars.

Key words: stellar collapse, particle acceleration, neutrino generation, magnetospheres of collapsing stars

1. Introduction

In this paper we will discuss the generation of particles, neutrino and photons in the magnetosphere of a magnetized star with the initial dipolar fields during its gravitational collapse. Gravitational collapse occurs at the final stage of stellar evolution. Gravitational collapse starts when the mass of a stellar core exceeds the Chandrasekhar limit and a star becomes dynamically unstable. After that, the star can evolve in several ways. Depending on the mass and chemical composition, a star can evolve into either of three relativistic objects, such as a white dwarf, neutron star or black hole (Zeldovich & Novikov, 1977; Shapiro & Teukolsky, 1985; Arnett, 1979). The progenitors of the relativistic massive objects could be red and blue giants, Wolf-Rayet (WR) stars, as well as supermassive stars (Cherepashchuk, 2003; Eldridge & Tout, 2004; Woosley & Heger, 2006). WR stars can originate from the helium cores of massive stars which lost their hydrogen shells or they can be formed as a result of either mass exchange in close binary systems or intense mass-loss of single stars due to strong stellar winds. The masses of CO-cores of WR stars are continuously distributed within the range from $5 M_{\odot}$ to $55 M_{\odot}$ (Cherepashchuk, 2003). WR stars are stars at advanced stages of stellar evolution. They are resulted from the collapse of carbon-hydrogen (SB) stellar cores and can be reckoned as the immediate progenitors of relativistic objects. The core collapse may be followed by the explosion and formation of type Ib or Ic supernovae. Moreover, relativistic objects can also be a result of the evolution of massive red and blue supergiants with normal chemical composition. For example, supergiant V3I was the progenitor of Supernova 1987A in LMC (Chevalier, 1995). O and B stars with masses $M > 10 M_{\odot}$ are early-type massive stars. They generate powerful stellar winds and emit intense infrared radiation. Some of them are radio-

frequency sources. The stellar wind velocities of O stars reach 3000 km/s, and the mass loss is $10^{-5} M_{\odot}$ per year.

The observational measurements of magnetic fields of different stars show the presence of strong magnetic fields in the upper atmospheres of WR and massive stars. For example, the β Cep (B2V) magnetic field is 360 Gs (Donati et al., 2001), the θ 1OriC (O4-6V) field is about 1100 Gs (Donati et al., 2002), and that one of ζ Sas (B2IV) is 335 Gs (Neiner et al., 2003). Far more intense magnetic fields are observed in very young massive stars W601 (NGC 6611) - up to 1400 Gs and OI 201 (NGC 2244) - up to 550 Gs (Alecian et al., 2008). The magnetic fields observed on the surface of the supergiant O9.7 ζ OrionisA were about 100 Gs (Bouret et al., 2008). 521 WDs with fields in the range from 1 to 733 MG were found in the Sloan Digital Sky Survey Data Release 7 (Kepler et al., 2013). The magnetic fields of these stars are of dipolar type (Kepler et al., 2013; Jordan, 2009). 67 new measurements of magnetic fields for 30 massive stars in the range from 10 G to 380 G made with FORS 2 at the VLT are given in the catalogue by Hubrig (Hubrig et al., 2013). The magnetic fields in about 65 from 550 stars were observed in the MiMeS project (Wade et al., 2013). The magnetic fields observed have important dipole components with polar strengths from several hundred G up to 20 kG.

We will examine gravitational collapse of a magnetized star with the initial dipolar magnetic fields and initial heterogeneous distribution of protons and electrons according to a power law (p), relativistic Maxwell (M) and Boltzmann (B) distributions.

The external electromagnetic field of a collapsing star changes according to the following law (Ginzburg & Ozernoi, 1964):

$$\begin{aligned} B_r &= 2r^{-3}\mu(t)\cos\theta, \\ B_\theta &= r^{-3}\mu(t)\sin\theta, \\ B_\varphi &= 0, \\ \mathcal{E}_\varphi &= -c^{-1}r^{-2}\frac{\partial\mu}{\partial t}\sin\theta, \\ \mathcal{E}_r &= \mathcal{E}_\theta = 0. \end{aligned} \quad (1)$$

Where B_r , B_θ , B_φ and \mathcal{E}_r , \mathcal{E}_θ , \mathcal{E}_φ are the components of magnetic and electric fields, respectively; $\mu(t) = (1/2)F_0R(t)$ is the magnetic momentum of the star with radius $R(t)$ that changes with time; $F_0 = 4\pi R_0^2 B_0^2$ is the initial magnetic flux of the star; R_0 is the initial radius of star; θ and φ are the polar and azimuth angles, respectively.

Full dipole magnetic field in the magnetosphere of a collapsing star is defined by the following equation (Kryvdyk, 2010):

$$B(r, \theta, R) = (B_r^2 + B_\theta^2 + B_\varphi^2)^{\frac{1}{2}} = \frac{\mu(t)}{r^3} (1 + 3 \cos^2 \theta)^{1/2} \quad (2)$$

Eqs. (1) describes the external electromagnetic field of a collapsing star with the Newtonian potential. Due to a large mass-to-charge ratio of a particle, Newton's method will be always suitable for description of the field in the magnetosphere of a collapsing star, excluding the area near the Schwarzschild radius. The stellar magnetosphere is compressed during a collapse as a result of the magnetic field strength increase. This variable magnetic field will generate the vortex electric field, which will accelerate the charged particles to relativistic energies. In the course of a core-collapse the magnetic field of a star changes according to the law (1) increasing up to 10^{12}G at the final stages of the collapse. The energy of particles changes because of betatronic acceleration, produced by the electric field E_φ , as well as energy losses due to magnetic braking.

During a collapse primary charged particles accelerate to relativistic energies (Kryvdyk, 1999; 2001; 2003; 2004; 2010). The energy of particles changes as per (Kryvdyk, 2010):

$$E/E_0 = (R_0/R)^{-A_1(\theta)}. \quad (3)$$

Where

$$A_1(\theta) = \frac{5}{3} k_1 (3 \cos^4 \theta + 1.2 \cos^2 \theta - 1) (1 + \cos^2 \theta)^{-2}$$

with $k_1 = 2$ for non-relativistic particles, and $k_1 = 1$ for relativistic particles; and E_0 is primary particle energy.

Figure 1 shows the distribution of particle energy in the magnetosphere according to a power law as a function $R_* = R_0/R$ and $E_* = E/E_0$ (Kryvdyk, 2010).

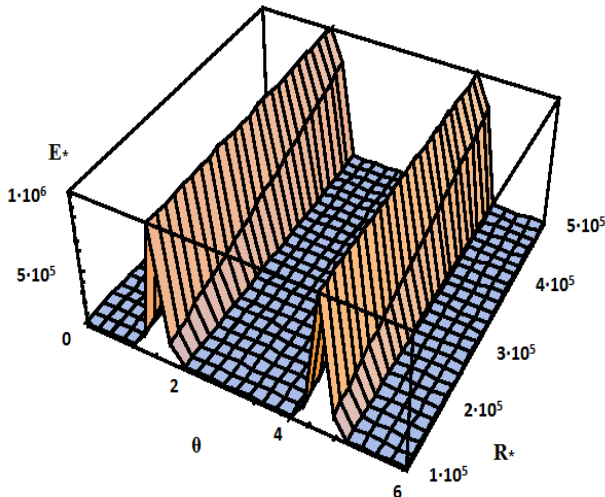

Figure 1: The change in particle energy distributed according to a power law during a collapse in the magnetosphere of a star with $R_* = R_0/R$, and $E_* = E/E_0$.

At the final stage of the collapse, electrons accelerate to energies $\leq 10^{11} \text{eV}$ while protons – to $E \leq 2 \cdot 10^{14} \text{eV}$ (Kryvdyk, 2010).

The initial magnetosphere of a collapsing star consists of protons and electrons distributed according to a power law (p), relativistic Maxwell (M), and Boltzmann (B) particle distributions; and the magnetosphere's density changes as r^{-3} . In the study by Kryvdyk (2010), the evolution of the particle energy spectrum for such distributions was determined for two extreme cases: (i) when energy losses due to magnetic braking do not affect the spectrum, and (ii) when they determine the spectrum evolution.

Figure 2 presents the particle number density $N_* = N/N_0$ in the magnetosphere near the star's surface as a function $R_* = R_0/R$ and polar angle θ for the power-law distribution of particles (Kryvdyk, 2010).

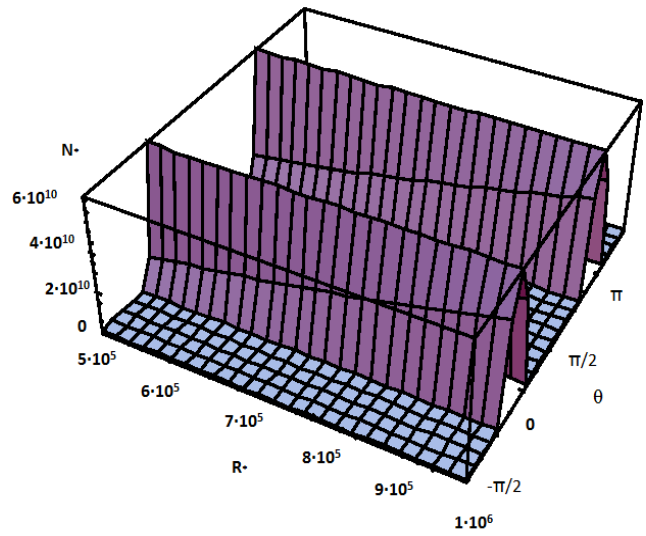

Figure 2: The particle number density in the magnetosphere near the star's surface at the final stage of the collapse with $R_* = R_0/R$ and $N_* = N/N_0$.

Interacting among themselves and with the magnetosphere's magnetic fields, accelerated charged particles will lose their energy due to ionization and radiation. At the same time, secondary charged particles (electrons, positrons, protons, and mesons), as well as neutrons, neutrino and photons are generated in the magnetospheres of collapsing stars. These secondary charged particles will also accelerate in the increasing magnetic fields during collapses. In the course of multiple cascade interaction, secondary particles will also generate other particles and photons. Therefore, the collapsing star magnetosphere consists of charged particles, neutrons, neutrinos and photons.

2. Generation of high-energy neutrinos, particles and photons in the collapsing star magnetosphere

In this section, we will consider in detail the generation of charged particles, neutrons, photons and neutrinos in the magnetosphere of collapsing stars.

The generation of these particles is shown in Table 1.

Table 1: The generation of particles in the magnetosphere of a collapsing star

Acceleration of the initial protons and electrons		
↓		
Generation and acceleration of secondary particles) →	Generation and acceleration of tertiary particle→...	...Multiple generation and acceleration of particles
Protons (p) Neutrons (n) Electrons (e⁻) Positrons (e⁺) Mesons (π, μ) Neutrino (ν) Antineutrino(ν⁻) Photons (γ)	Protons (p) Neutrons (n) Electrons (e⁻) Positrons (e⁺) Mesons (π, μ) Neutrino (ν) Antineutrino(ν⁻) Photons (γ)	Protons (p) Neutrons (n) Electrons (e⁻) Positrons (e⁺) Mesons (π, μ) Neutrino (ν) Antineutrino(ν⁻) Photons (γ)

Especially important are cascade showers of charged particles, neutrons, neutrinos and photons generated in the magnetosphere. These processes are very effective for the formation of magnetosphere of a collapsing star.

Secondary charged particles, neutrons, neutrinos and photons can be generated in the magnetosphere of a collapsing star, namely:

- 2.1. π-mesons, μ-mesons, electrons, positrons and neutrinos produced in nuclear interactions;
- 2.2. electron-positron pairs resulted from annihilation of gamma quanta in a nuclear field;
- 2.3. electron-positron pairs resulted from the collision of charged particles;
- 2.4. electron-positron pairs resulted from photon-photon collisions;
- 2.5. μ-meson pairs produced by passing of gamma quanta in a nuclear field;
- 2.6. recoil electrons resulted from the collision of charged particles;
- 2.7. electron-positron pairs produced in a strong curvilinear magnetic field.

2.1. Generation of π-mesons, μ-mesons, electrons, positrons and neutrinos by nuclear interactions in the magnetosphere of a collapsing star

In earlier studies of the author (Kryvdyk, 1999; 2001; 2003; 2004; 2010) it was reported that primary protons and electrons accelerate in the magnetosphere of a collapsing star to relativistic energies. The accelerated protons will interact with other protons in the magnetosphere, generating mesons in the following nuclear interactions (Leng, 1974; Hajakawa, 1978a; 1978b):

$$\begin{aligned}
 p + p &\rightarrow p + p + n_1 (\pi^+ + \pi^-) + n_2 \pi^0, \\
 p + p &\rightarrow p + n + \pi^+ + n_3 (\pi^+ + \pi^-) + n_4 \pi^0, \\
 p + p &\rightarrow n + n + 2\pi^+ + n_5 (\pi^+ + \pi^-) + n_6 \pi^0, \\
 p + p &\rightarrow D + \pi^+ + n_7 (\pi^+ + \pi^-) + n_8 \pi^0,
 \end{aligned} \tag{4}$$

where p – protons; n – neutrons; D – deuterons; n₁-n₂ – positive integers.

The secondary electrons, positrons, photons and neutrinos will generate in the later on by decay of mesons:

$$\begin{aligned}
 \pi^\pm &\rightarrow \mu^\pm + \nu_\mu/\bar{\nu}_\mu \\
 \pi^0 &\rightarrow \gamma + \gamma \\
 \mu^\pm &\rightarrow e^\pm + \nu_e/\bar{\nu}_e + \nu_\mu/\bar{\nu}_\mu
 \end{aligned} \tag{5}$$

For relativistic protons with energy from 290 MeV to 1 GeV only one with next reaction can be possible (Leng, 1974):

$$p + p \rightarrow p + n + \pi^+, \text{ or } p + p + \pi^0, \text{ or } D + \pi^+. \tag{6}$$

The minimum proton energy E_{min} for the generation of π-mesons is

$$E_{min} = \frac{Y^2 m_\pi^2 c^4}{2m_p c^2} + 2Y m_\pi c^2 \approx Y(280 + 10Y)[\text{MeB}],$$

where $m_\pi c^2$ and $m_p c^2$ the rest energy of a π-meson and a proton, respectively.

π-mesons can be generated only by protons with energy higher than 290 MeV. These protons can accelerate in the variable magnetic fields in the magnetosphere of a collapsing star (Kryvdyk, 1999; 2001; 2003; 2004; 2010). Neutral neutrons are also generated by reactions (4) - (6). Neutrons do not interact with the magnetic fields; and therefore, they freely go out of the magnetosphere, forming the neutron wind around the collapsing star. When there are sufficient amount of free neutrons and protons, neutrinos can be resulted from Urca processes in which neutrons and protons capture electrons or positrons, causing radiation of energy in the form of neutrinos in the following reactions (Chiu & Salpeter, 1964):

$$\begin{aligned}
 p + e^- &\rightarrow n + \nu_e, \\
 n + e^+ &\rightarrow p + \bar{\nu}_e, \\
 n &\rightarrow p + e^- + \bar{\nu}_e,
 \end{aligned} \tag{7}$$

Intense magnetic fields will influence the rate of Urca-reactions. In very strong magnetic fields ($H \geq 4 \cdot 10^{13}$ Gs) urca- processes can arise in hundred time (Canuto V., et al. 1970, Fassio-Canuto 1969).

Quasi-free pions will be also generated in the magnetosphere of a collapsing star resulting from reactions (4) and (6). Therefore, the following Urca-reactions in which neutrinos, electrons and pions are generated, are possible in the magnetosphere:

$$\begin{aligned}
 \pi^- + n &\rightarrow n + e^- + \bar{\nu}_e, \\
 n + e^- &\rightarrow n + \pi^- + \nu_e, \\
 \pi^- + n &\rightarrow n + \mu^- + \bar{\nu}_\mu, \\
 n + \mu^- &\rightarrow n + \pi^- + \nu_\mu.
 \end{aligned} \tag{8}$$

2.2. Generation of electron-positron pairs as results of annihilation of gamma quanta in a nuclear field

The electron-positron pairs will be generated during passing of gamma-photons with energy $h\nu > 2m_e c^2 = 1.022 \text{ MeV}$ in the nuclear Coulomb field with charge eZ ,

where $m_e c^2 \approx 0.511 \text{ MeV}$ is the electron rest energy. For photons with energy $h\nu \gg m_e c^2$ the cross-section of electron-positron pair generation is as follows (Leng, 1974):

$$\begin{aligned} \sigma(h\nu) &= 4\alpha Z^2 r_0^2 \left[\frac{2}{9} \ln\left(\frac{2h\nu}{m_e c^2}\right) - \frac{109}{54} \right] \text{ for } h\nu \ll \frac{m_e c^2}{\alpha Z^{1/3}}, \\ \sigma(h\nu) &= 4\alpha Z^2 r_0^2 \left[\frac{2}{9} \ln\left(\frac{191}{Z^{1/3}}\right) - \frac{1}{54} \right] \text{ for } h\nu \gg \frac{m_e c^2}{\alpha Z^{1/3}}, \end{aligned} \quad (9)$$

where $r_0 = e^2/m_e c^2 \approx 2.8 \cdot 10^{-13} \text{ cm}$ is the classical electron radius; $\alpha \approx 1/137$ is the fine-structure constant. The value $4\alpha r_0^2 \approx 2.3 \cdot 10^{-27} \text{ cm}^2$.

The main nuclei in the magnetosphere are protons ($Z=1$); therefore, the cross-sections of electron-positron pair generation due to the interaction of gamma-photons with protons are:

$$\begin{aligned} \sigma_{php}(h\nu) &\approx 2.3 \cdot 10^{-27} \left[\frac{2}{9} \ln\left(\frac{2h\nu}{m_e c^2}\right) - \frac{109}{54} \right] \text{ for } h\nu \ll 70 \text{ MeV}, \\ \sigma_{php}(h\nu) &\approx 2.3 \cdot 10^{-27} \left[\frac{2}{9} \ln(191) - \frac{1}{54} \right] \text{ for } h\nu \gg 70 \text{ MeV}. \end{aligned} \quad (10)$$

The numerical values of nuclear cross-section in this case are:

$$\begin{aligned} \sigma_{php}(h\nu) &\approx 4.2 \cdot 10^{-28} \text{ cm}^2 \text{ for } h\nu \ll 70 \text{ MeV}, \\ \sigma_{php}(h\nu) &\approx 9.4 \cdot 10^{-27} \text{ cm}^2 \text{ for } h\nu \gg 70 \text{ MeV}. \end{aligned} \quad (11)$$

2.3. Generation of electron-positron pairs by the interaction of charged particles

The electron-positron pairs will be resulted from the interaction of electrons with protons. The cross-section for the electron interactions is as follows (Leng, 1974):

$$\sigma_{ep}(h\nu) = \frac{28}{27\pi} \alpha^2 r_0^2 \ln(1/\alpha) \left[3 \ln\left(\frac{E_e}{m_e c^2}\right) \ln\left(\frac{E_e}{191 m_e c^2}\right) + \ln^2(191) \right], \quad (12)$$

where E_e is electron energy.

For the numerical values $\alpha \approx 1/137$ and $r_0 \approx 2.8 \cdot 10^{-13} \text{ cm}$, $m_e c^2 \approx 0.511 \text{ MeV}$ we obtain the following cross-sections:

$$\sigma_{ep}(h\nu) \approx 6.8 \cdot 10^{-30} [3 \ln(2 E_e) \ln(10^{-2} E_e) + 27.6]. \quad (13)$$

Their numerical values is

$$\sigma_{ep}(h\nu) \approx 6.3 \cdot 10^{-29} \text{ cm}^2 \quad (14)$$

2.4. Generation of electron-positron pairs in photon-photon collisions

Electron-positron pairs can be also generated in the magnetosphere as a result of collisions of two photons with energies E_1 and E_2 (given that $E_1 E_2 > (m_e c^2)^2$). The cross-section for this interaction is as follows (Leng, 1974; Heitel, 1954):

$$\sigma_{2ph}(E_1, E_2) = \frac{\pi r_0^2}{2} (1 - \beta^2) \left[2\beta(\beta^2 - 1) + (3 + \beta^4) \ln\left(\frac{1+\beta}{1-\beta}\right) \right], \quad (15)$$

Where $\beta = \left[1 - \frac{(m_e c^2)^2}{E_1 E_2} \right]^{1/2}$, βc is the electron velocity in the center-of-mass system.

Value $\sigma_{2ph}(E_1, E_2)$ change in range

$$5.2 \cdot 10^{-26} \leq \sigma_{2ph}(E_1, E_2) \leq 2.9 \cdot 10^{-25} \text{ cm}^2 \quad (16)$$

for $0.85 \leq \beta \leq 0.999$.

2.5. Generation of μ -meson pairs by annihilation of gamma quanta in nuclear field

If the energy of a gamma photon exceeds the threshold energy $2m_\mu c^2 \sim 211 \text{ MeV}$, then a μ^\pm pair is to be produced in the interaction of this photon with the nuclear Coulomb field. The cross-section of this interaction can be obtained from equation (9) just by replacing the electron mass m_e with the meson mass m_μ . The value $m_e/m_\mu \sim (1/207)^2 \sim 1.37 \cdot 10^{-5}$; thus, for μ -meson pairs

$$\sigma_{p\gamma}(h\nu) \approx 1.29 \cdot 10^{-32} \text{ cm}^2 \quad (17)$$

2.6. Generation of recoil electrons in collisions of charged particles

Recoil electrons will be generated in collisions of charged particles with other particles. The magnetosphere of a collapsing star consists substantially of electrons and protons. The cross-section of the generation of recoil electrons with energy E_e in collisions with relativistic protons with energy E_p and charge eZ is as follows (Leng, 1974; Hajakawa, 1978a; 1978b):

$$\sigma_p(E_p, E_e) dE_e \approx 2\pi r_0^2 \frac{m_e c^2}{\beta_p^2 E_e^2} dE_e, \quad (18)$$

where $\beta_p = \left[1 - (m_p c^2)^2 / E_p E_p \right]^{1/2}$, $\beta_p c$ is the proton velocity in the center-of-mass system.

The numerical value this cross-section is

$$\sigma_p(E_p, W_e) dW_e \approx 2.55 \cdot 10^{-25} \frac{1}{\beta_p^2 W_e^2} dW_e. \quad (19)$$

The upper limit of energy for this process is $E_e \approx pc$, where p is impulse of the incident particle.

As follows from section 2, the initial electrons and protons in the magnetosphere of collapsing star will accelerate to relativistic energy. The relativistic electron will lose their energy in the magnetic fields significant fast from proton, and therefore the electron lifetime is significant less from the proton lifetime. In the magnetosphere will generate also the second electrons by the mutual collisions protons with electrons.

2.7. Generation of electron-positron pairs in a strong magnetic field

If the magnetic fields arise to critical value

$$B_c = m_e^2 c^3 / e \hbar = 4.4 \cdot 10^{13} \text{ G}, \quad (20)$$

where m and e are the electron mass and charge, respectively; h is Planck's constant; then the electron-positron plasma will be produced via direct vacuum decay.

In the system with a sufficiently strong curvilinear magnetic field the decay can occur in a much weaker magnetic field. This mechanism is effective for the formation of magnetospheres in pulsars with strong surface magnetic fields (Goldreich and Julian 1969; Sturrock, 1971; Ruderman and Sutherland, 1975). By rotating neutron stars with radius R and the magnetic fields B near surface will generate the parallel electric fields

$$E_{\parallel} \approx \Omega RB/c, \quad (21)$$

where Ω is the rotational velocity, and c is the speed of light.

The electrons and positrons will accelerate to relativistic energies in this electric field. Moving along the curvilinear magnetic field, they will emit the so-called curvature photons whose energy is sufficient to produce electron-positron pairs in the magnetic field. These pairs also accelerate to high energies in parallel electric fields (2) where they can produce pairs themselves, emitting curvature photons. This is the main mechanism of generation of multiple electrons, positrons and γ photons. The multiplication coefficient will increase as the particles produced in a high Landau level in the magnetic field emit synchrotron radiation, i.e. synchrophotons, which can also produce pairs.

At the collapse's final stage, magnetic fields near the star's surface can increase to value $B \sim 10^{12}$ Gs; thus, the generation of multiple electrons, positrons and γ photons in the curvilinear magnetic field can be the effective mechanism of formation of electron-positron pairs in magnetosphere of collapsing stars.

3. Neutrino generation in the magnetosphere of a collapsing star

Secondary neutrons, protons, electrons, positrons and photons are generated in the magnetosphere of a collapsing star as results of different processes. These particles will produce neutrinos by interactions with particles and fields in the magnetosphere. In the neutral non-degenerate plasma the main processes of neutrino generation are the following (Leng, 1974; Fassio-Canuto, 1969; Braaten & Segel, 1993; Bruenn, 1985; Dicus, 1972; Itoh et al., 1989; Koers & Wijers, 2005; Lattimer et al., 1991; Munakata et al., 1985; Qian & Woosley, 1996; Ratkovic et al., 2003; Reynoso et al., 2006):

- 3.1. Bremsstrahlung by electron-atom collision
 $e^- + (Z, A) \rightarrow (Z - 1, A) + \nu_e + \bar{\nu}_e$;
- 3.2. Neutrino emission in Urca processes in the magnetosphere;
- 3.3. Bremsstrahlung of the charged particles in strong magnetic fields;
- 3.4. Photoneutrino reactions $e^{\pm} + \gamma \rightarrow e^{\pm} + \nu_e + \bar{\nu}_e$;
- 3.5. Plasmons decay $\Gamma \rightarrow \nu_e + \bar{\nu}_e$;
- 3.6. Annihilation of electron-positron pairs
 $e^+ + e^- \rightarrow \nu_e + \bar{\nu}_e$;
- 3.7. Generation of neutrinos in meson decay.

We will consider these processes in detail in next subsection.

3.1. Neutrino emission by electron-atom collision

Neutrino can be emitted due to electron-atom bremsstrahlung, when a free electron collides with a nucleus (Z, A). As a result a pair of neutrino-antineutrino will be produced (Leng, 1974; Pontekorvo, 1959):

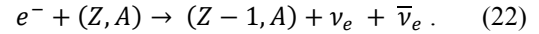

For this process the neutrino luminosity is as follows (Koers & Wijers, 2005; Qian & Woosley, 1996; Reynoso et al., 2006):

$$Q_{\nu br} = 1.5 \cdot 10^{27} T_{11}^{5.5} \rho_{10}^2 \frac{Erg}{cm^3 \cdot sec}, \quad (23)$$

where the temperature is $T_{11} = T/10^{11}$ K, the baryon density is $\rho_{10} = \rho/10^{10}$ g/cm³. From now on the unit of neutrino luminosity Q_{ν} is $\frac{Erg}{cm^3 \cdot sec}$.

By replacing temperature T with energy E (eV) from the relation

$$T[K] = E/k = 1,16 \cdot 10^4 E[eV], \quad (24)$$

we obtain

$$Q_{\nu br} = 3.5 \cdot 10^{49} E_{11}^{5.5} \rho_{10}^2, \quad (25)$$

where the unit energy E is eV.

The energy of particles in the magnetosphere during gravitational collapse increase as $E/E_0 = (R_0/R)^{-A_1(\theta)}$ (see Eq. 3).

Therefore, the neutrino luminosity in the magnetosphere due to electron-atom bremsstrahlung is

$$Q_{\nu br} = 3,4 \cdot 10^{49} \left[\frac{E_0 \left(\frac{R_0}{R}\right)^{-A_1(\theta)}}{10^{11}} \right]^{5.5} \rho_{10}^2. \quad (26)$$

During collapse the electron energy accelerate to $E_e \approx 10^{11}$ eV, and the energy of protons increases to $E_p \approx 10^{14}$ eV (Kryvdyk, 2010); the proton density increases to $\rho_p = 10^{12}$ proton/cm³ $\approx 1.7 \cdot 10^{12}$ g/cm³. For such energy and density, at the final stage of collapse ($R_0/R = 10^6$) the neutrino luminosity due to electron-proton collisions in the equatorial regions of the magnetosphere ($\theta = \pi/2$) can reach the extreme value

$$Q_{\nu br} \approx 3.3 \cdot 10^{18} \frac{Erg}{cm^3 \cdot sec}. \quad (27)$$

3.2. Neutrino radiation by Urca processes in the magnetosphere

For the magnetosphere of a collapsing star which consists of electrons, positrons, protons and neutrons, the particular interest is focused on the effects of the electron capture on protons, as well as that one of the positron capture by the neutron reaction – the so-called Urca-process:

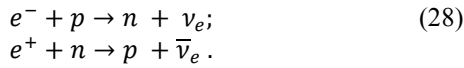

The last Urca-processes are the main processes in the environment with nuclei of small density. The neutrino luminosity for Urca-processes is the following (Qian & Woosley, 1996):

$$Q_{vURCA} = 9.0 \cdot 10^{31} T_{11}^6 \rho_8, \quad (29)$$

where temperature $T_{11} = T/10^{11}K$, $\rho_8 = \rho/10^8 g/cm^3$ is the baryon density in the magnetosphere.

If energy E is measured in eV , we obtain

$$Q_{vURCA} = 2.2 \cdot 10^{56} E_{11}^6 \rho_8, \quad (30)$$

where $E_{11} = E/10^{11}eV$.

The neutrino luminosity for Urca-processes greatly depends on the energy of particles. The energy of particles grows very quickly during collapse; thus, Urca-processes will play a significant role in the neutrino generation in the magnetosphere. The neutrino luminosity in the magnetosphere for Urca-process changes during collapse as

$$Q_{vURCA} = 2.2 \cdot 10^{56} \left[\frac{E_0 \left(\frac{R_0}{R}\right)^{-A_1(\theta)}}{10^{11}} \right]^6 \rho_8. \quad (31)$$

At the final stages of the collapse ($R_0/R=10^6$) in the equatorial regions of the magnetosphere ($\theta=\pi/2$) the protons can accelerate to energies $E_p \leq 10^{14} eV$, and the magnetosphere density grows up to $\rho_p = 10^{12} proton/cm^3 = 10^{-12} g/cm^3$. If in the magneto-sphere the electrons capture on protons with energy $E_p \leq 10^{14} eV$, then neutrino will be produced with the speed

$$Q_{vURCA} \leq 2.2 \cdot 10^{56} \frac{Erg}{cm^3 \cdot sec}. \quad (32)$$

This is a very powerful flow of neutrinos, which will be rapidly frozen in the magnetosphere during gravitational collapse.

3.3. Neutrino generation due to of electron braking radiation in a strong magnetic field

Neutrinos can be also produced due to synchrotron radiation by electrons accelerated in the strong magnetic field. The neutrino luminance for this process for a relativistic degenerate electron is as follows (Canuto et al., 1970; Fassio-Canuto, 1969; Landstreet, 1967):

$$Q_{v eB} = \begin{cases} 3 \cdot 10^{-44} B_8^6 T_7 \rho^4, & \text{for } B_8 \rho^{\frac{2}{3}} \leq 8 \cdot 10^6 T_7, \\ 4 \cdot 10^{-7} B_8^{\frac{2}{3}} T_7^{\frac{19}{3}} \rho^{\frac{4}{3}}, & \text{for } B_8 \rho^{\frac{2}{3}} \geq 8 \cdot 10^6 T_7, \end{cases} \quad (33)$$

where $B_8 = B/10^8$.

For magnetosphere of collapsing stars at the final stage of gravitational collapse the magnetic fields are $B =$

$10^{12}G$, electron energy is $E_e \leq 10^{12}eV$, the electron density is

$$\rho_e = 10^{12} electron/cm^3 = 9 \cdot 10^{-16} g/cm^3.$$

For such magnetosphere the values $B_8 \rho^{\frac{2}{3}} \approx 10^{-6}$; $8 \cdot 10^6 T_7 \approx 6 \cdot 10^{16}$. As follows from this the estimation, $B_8 \rho^{\frac{2}{3}} \ll 8 \cdot 10^6 T_7$. Therefore, the extreme neutrino luminance for electron braking radiation

$$Q_{v eB} = 3 \cdot 10^{-44} B_8^6 T_7 \rho^4 \approx 3.3 \cdot 10^{-71} \frac{Erg}{cm^3 \cdot sec}. \quad (34)$$

This value is very small; hence, it does not enable us to examine the neutrino radiation due to the electron braking in the magnetosphere.

3.4. Generation of neutrinos due to photoneutrino processes

Neutrinos will be also produced in the collisions of photons with electrons and positrons in photoneutrino reactions (Ritus, 1961; Chiu & Stabler, 1961; Petrosian et al., 1967):

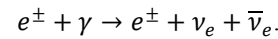

The neutrino luminosity for the photoneutrino processes in hot plasma with is determined as follows (Dutta et al., 2004; Koers & Wijers, 2005; Reynoso et al., 2006)

$$Q_{v photo} = 1.1 \cdot 10^{31} T_{11}^9, \quad (35)$$

where $T_{11} = T/10^{11}K$.

If the energy E is measured in eV , then

$$Q_{v photo} = 4,2 \cdot 10^{67} E_{11}^9. \quad (36)$$

For magnetospheres of collapsing stars

$$Q_{v photo} = 4,2 \cdot 10^{67} [E_0 \left(\frac{R_0}{R}\right)^{-A_1(\theta)} / 10^{11}]^9. \quad (37)$$

At the final stage of gravitational collapse ($R_0/R=6$) the electrons can accelerate to the energy $E_e \leq 10^{11}eV$. The extreme neutrino luminosity for photoneutrino processes for such hot plasma in the equatorial regions the magnetosphere ($\theta=\pi/2$) is

$$Q_{v photo} \leq 4,2 \cdot 10^{67} \frac{Erg}{cm^3 \cdot sec}, \quad (38)$$

This value is very big, so we can make conclusions about strong cooling magnetosphere due to neutrino emission due to photoneutrino processes in magnetosphere during collapse.

3.5. Generation of neutrino-antineutrino pairs by plasmon decay

When a photon moves through ionized gas, a virtual electron-hole pair (plasmon) will appear. This plasmon decays into neutrino-antineutrino pairs

$$\Gamma \rightarrow \nu_e + \bar{\nu}_e. \quad (39)$$

The neutrino luminosity for such process is the following (Ratcovich et al., 2003; Koers and Wijers, 2005; Reynoso et al., 2006):

$$Q_{\nu \text{ plasma}} = 7.1 \cdot 10^{26} T_{11}^9. \quad (40)$$

Replacing the temperature T (K) on energy E (eV), we obtain

$$Q_{\nu \text{ plasma}} = 2.7 \cdot 10^{63} E_{11}^9. \quad (41)$$

For magnetospheres of collapsing stars

$$Q_{\nu \text{ plasma}} = 2.7 \cdot 10^{63} [E_0 \left(\frac{R_0}{R}\right)^{-A_1(\theta)} / 10^{11}]^9 \quad (42)$$

The electrons can accelerate in magnetosphere to the energy $E_e \leq 10^{11} \text{eV}$.

The extreme neutrino luminosity for plasmon decay in the equatorial regions of the magnetosphere ($\theta=\pi/2$) at the final stage of gravitational collapse ($R_0/R=6$) is

$$Q_{\nu \text{ plasma}} \leq 2.7 \cdot 10^{63} \frac{\text{Erg}}{\text{cm}^3 \cdot \text{sec}}. \quad (43)$$

3.6. Formation of neutrino-antineutrino pairs in annihilation of electron-positron pairs

As follows from section 3, large number of electron-positron pairs will be generated in the magnetosphere of a collapsing star. During the annihilation of these pairs neutrino pairs can be formed (Chiu and Stabler, 1961; Chiu, 1961; Chiu and Morrison, 1960):

$$e^+ + e^- \rightarrow \nu_e + \bar{\nu}_e.$$

The neutrino luminosity for this process as follows (Itoh et al., 1989; Koers & Wijers, 2005; Reynoso et al., 2006)

$$Q_{\nu \text{ pair}} = 3.6 \cdot 10^{33} T_{11}^9. \quad (44)$$

By replacing the temperature on energy E (eV), we obtain

$$Q_{\nu \text{ pair}} = 1.37 \cdot 10^{70} E_{11}^9. \quad (45)$$

For magnetospheres of collapsing stars we obtain

$$Q_{\nu \text{ pair}} = 1.37 \cdot 10^{70} [E_0 \left(\frac{R_0}{R}\right)^{-A_1(\theta)} / 10^{11}]^9. \quad (46)$$

The extreme neutrino luminosity for plasmon decay in the equatorial regions of the magnetosphere ($\theta=\pi/2$) at the final stage of gravitational collapse ($R_0/R=6$) due to annihilation of electrons and positrons with the energy $E_{e^\pm} = 10^{11} \text{eV}$ is

$$Q_{\nu \text{ pair}} = 1.37 \cdot 10^{70} \frac{\text{Erg}}{\text{cm}^3 \cdot \text{sec}}. \quad (47)$$

3.7. Generation of neutrino by mesons decay

If the plasma temperature exceeds $6 \cdot 10^{11} \text{K}$ ($E = 50 \text{MeV}$), in the thermal radiation field of stars, neutrinos can be generated due to meson decay in the magnetosphere (Arnett, 1967):

$$\begin{aligned} \pi^\pm &\rightarrow \mu^\pm + \nu_\mu / \bar{\nu}_\mu, \\ \mu^\pm &\rightarrow e^\pm + \nu_e / \bar{\nu}_e + \nu_\mu / \bar{\nu}_\mu. \end{aligned} \quad (48)$$

The neutrino luminosity for μ -meson decay is the following (Hansen, 1968):

$$Q_{\nu \mu} = 4.32 \cdot 10^{38} T_{11}^3 \text{ for } 50 \leq T_9 \leq 500. \quad (49)$$

If energy E is in eV, then

$$Q_{\nu \mu} \approx 6.74 \cdot 10^{50} E_{11}^3 \quad (50)$$

For magnetospheres of collapsing stars

$$Q_{\nu \text{ photo}} = 6.74 \cdot 10^{50} [E_0 \left(\frac{R_0}{R}\right)^{-A_1(\theta)} / 10^{11}]^3. \quad (51)$$

The formation of π -mesons is possible only for very high-energy protons (over 290 MeV). These protons will accelerate in a variable magnetic field of the magnetosphere of a collapsing star.

At the final stage of collapse the proton energy E can accelerate to 10^{14}eV ; therefore, the neutrino luminosity for μ -meson decay in magnetosphere can increase to the value

$$Q_{\nu \mu} \approx 6.74 \cdot 10^{59} \frac{\text{Erg}}{\text{cm}^3 \cdot \text{sec}} \quad (52)$$

4. Neutrino absorption and scattering in magnetosphere during collapse

Neutrino are absorbed and scattered due to the following processes:

1. e^\pm -neutrino scattering: $\nu_i + e^\pm \rightarrow \nu_i + e^\pm$;
2. Absorption neutrino by neutron: $\nu_e + n \rightarrow p + e^-$;
3. Absorption antineutrino by proton: $\bar{\nu}_e + p \rightarrow n + e^+$.

Here we assume that all the particles are non-degenerate.

4.1. Electron and positron scattering

The cross-section neutrino scattering of electrons in a plasma is the following (Tubbs & Schramm, 1975):

$$\sigma_{\nu e} = \frac{3G_F^2 \hbar^2 c^2}{2\pi} \left[(c_V + c_A)^2 + \frac{1}{3} (c_V - c_A)^2 \right] (kT) E_\nu. \quad (53)$$

Where

$$\begin{aligned} c_V &= 1/2 + 2 \sin^2 \theta_W, \\ c_A &= 1/2; \sin^2 \theta_W = 0.22. \\ G_F^2 \hbar^2 c^2 &= 5.3 \cdot 10^{-44} \text{cm}^2 \text{MeV}^{-2}. \end{aligned}$$

The average thermal neutrino distribution $\langle E_\nu \rangle = 3.15 kT$. It applies to the electron-neutrinos, which interact with electrons through both the charged and neutral current.

The neutrino mean free path due to combined electron-positron scattering as follows from (Koers, 2005)

$$\lambda^{-1}(\nu_i, e^\pm) = \sigma(\nu_i, e^\pm)n_{e^-}.$$

Because the electron and positron density scales as T^3 , the pass length is proportional to T^5 .

For magnetospheres of collapsing stars with the electron energy $E_e \leq 10^{11} eV$ and electron density $\rho_e = 10^{12} \text{ electron/cm}^3 = 9 \cdot 10^{-16} \text{ g/cm}^3$ the neutrino mean free path due to combined electron-positron scattering is

$$\lambda(\nu_i, e^\pm) \leq 10^{14} \text{ cm}. \quad (54)$$

4.2. Neutron and proton absorption

Electron-neutrinos and antineutrinos can be absorbed by neutrons and protons through the charged interaction. The cross-section is (Tubbs & Schramm, 1975)

$$\sigma_{\nu p} = \frac{G_F^2 \hbar^2 c^2}{\pi} (1 + 3\alpha^2) E_\nu^2 g(E_\nu).$$

where

$$g(E_\nu) = \left(1 \pm \frac{Q}{E_\nu}\right) \left[1 \pm 2 \frac{Q}{E_\nu} + \frac{Q^2 - (\pm m_e^2)}{E_\nu^2}\right]^{1/2}$$

where $\alpha = -1.26$ is the nuclear axial coupling coefficient and $Q = 1.3 \text{ MeV}$ is the neutron-proton mass difference. The positive sign applies to neutrino capture on neutrons, the negative sign to antineutrino capture on protons.

The pass length for neutrino-proton scattering is

$$\lambda^{-1}(\nu_i, p) = \sigma(\nu_i, p)(0.5n_p)$$

This value is proportional to T^2 .

For magnetospheres of collapsing stars with proton energy $E \leq 10^{14} eV$ and proton density $\rho_p = 10^{12} \text{ proton/cm}^3$ the neutrino mean free path due to combined electron-positron scattering is

$$\lambda(\nu_i, p) \leq 10^2 \text{ cm}. \quad (55)$$

As follows from Eqs. (54) and (55), $\lambda(\nu_i, e^\pm) \gg \lambda(\nu_i, p)$.

Therefore, electron-neutrinos and antineutrinos will be absorbed in the magnetosphere by neutrons and protons through the charged interaction.

Neutrinos will be absorbed in the magnetosphere due to their interaction with matter. The interaction cross-section for electron neutrino and muon neutrinos with the substance is very small and is approximately 10^{-44} cm^2 for neutrinos with energies 1 MeV. The loss rate of neutrino due to scattering on electrons, protons or neutrons is (Lattimer et al., 1991; Koers & Wijers, 2005):

$$\begin{aligned} P_{\nu e} &\approx 9.1 \cdot 10^{-35} N_e N_\nu T_9^2 [s^{-1} \text{ cm}^{-3}], \\ P_{\nu p} &\approx 1.5 \cdot 10^{-6} N_p N_\nu T_9^5 [s^{-1} \text{ cm}^{-3}], \end{aligned} \quad (56)$$

where

$$N_\nu = 7.65 \cdot 10^{27} T_9^3 \quad (57)$$

is a number of neutrino in the unit of volume, N_e is a number of electrons, and N_p is a number of protons or neutrons.

The main part neutrino will be absorbed in the magnetosphere on protons and neutrons. By substituting (57) for (56) and replacing temperature $T(K)$ on energy $E(eV)$, we obtain the rate of neutrino scattering on protons or neutrons

$$P_{\nu p} \approx 3.77 \cdot 10^{69} N_p E_{11}^8, \quad (58)$$

where $E_{11} = E/10^{11} eV$.

For magnetospheres of collapsing stars

$$P_{\nu p} \approx 3,77 \cdot 10^{69} N_p [E_0 \left(\frac{R_0}{R}\right)^{-A_1(\theta)} / 10^{11}]^8. \quad (59)$$

5. Numerical evaluation of neutrino luminosity in the magnetosphere of a collapsing star

As follows from the previous sections, in the magnetosphere of a collapsing star the neutrino flux will be generated due to various mechanisms. Neutrinos can go out of the magnetosphere. As a result, this magnetosphere loses its energy. The rate of energy loss due to neutrino luminosity for different mechanisms can be determined by formulae (14), (16), (20), (22), (24), (26) and (29). The most neutrino will be generated in the magnetosphere of a collapsing star due to the pair annihilation. Therefore, the neutrino luminosity in the magnetosphere of a collapsing star can be written down as

$$Q_\nu = Q_{\nu \text{ pair}} = 1.37 \cdot 10^{70}. \quad (60)$$

The neutrino luminosity from the whole magnetosphere of a collapsing star can be obtained by integrating the specific neutrino luminosity for the whole magnetosphere:

$$L_\nu = \int Q_\nu dV, \quad (61)$$

where dV – the volume element of magnetosphere.

As neutrinos do not interact practically with magnetic fields, their distribution in the magnetosphere is spherically symmetric. For such case

$$dV = 4\pi r^2 dr. \quad (62)$$

Substituting (60) and (62) into (61) and integrating by volume within $R \leq r \leq R_m$, we obtain the full neutrino luminosity for the magnetosphere of a collapsing star

$$L_\nu \approx 8 \cdot 10^{70} (R_m - R)^3. \quad (63)$$

Here R is the radius of star; R_m is the magnetosphere radius of ($R \leq R_m \leq r$).

This formula allows to determine the full neutrino luminosity in the magnetosphere.

For regions near surface of collapsing stars ($R_m \geq R$)

$$L_\nu \geq 8 \cdot 10^{70} \text{ Erg/sec} . \quad (64)$$

As we can see, the magnetospheres of collapsing stars are the very powerful sources of neutrinos, which are generated by the nuclear reactions and the annihilation of electron-positron pairs. These neutrinos will go out of the magnetosphere thereby cooling it.

5. Conclusion

The primary protons and electrons are accelerated in the magnetosphere of a collapsing star to relativistic energies during gravitational collapse. Later on, the secondary charged particles (electrons, positrons, protons and mesons), neutrons, neutrinos and gamma photons will be generated in the magnetosphere of a collapsing star due to different interaction between the particles and fields. The charged secondary particles will be also accelerated in the increasing magnetic field, generating the cascade charged particles, neutrons, neutrinos and photons. As results of these processes, the magnetosphere of the collapsing star will be formed. This magnetosphere consists of protons (p), electrons (e), positrons (e^+), neutrons (n), mezosons (π , μ), neutrinos (ν), and photons (γ).

Being generated in the magnetosphere of a collapsing star, some part of neutrinos will escape the magnetosphere thereby cooling magnetosphere with very high rate. For the subsequent existence of the energy balance in the magnetosphere, the continuous energy flow from the star into the magnetosphere is required. This energy flow can be provided by stellar winds, accelerating in strong magnetic fields during a stellar collapse.

Some part of particles and neutrinos go out from the magnetosphere in the interstellar medium. This means that magnetospheres of stars during their gravitational collapse are the powerful sources of particles and neutrinos in our Galaxy and other galaxies. The contribution of these sources in the general flux of cosmic rays and neutrinos will be investigated in the further study.

References

- Alecian E., et al.: 2008, *Astron. and Astroph.*, **481**, L99.
 Arnett W. D.: 1967, *Canad. J. Phys.*, **45**, 1621.
 Arnett W. D.: 1979, *Gravitational collapse of evolved stars as a problem in physics*. In: "Sources of gravitational radiation". Ed. Smarr. Cambridge, pp. 163-174.
 Baiotti L., Giacomazzo B., Rezzolla L.: 2008, *Phys. Rev. D*, **78**, id. 084033.
 Bouret J.-C. et al. : 2008, *MNRAS*, **389**, 75.
 Braaten E., Segel D.: 1993, *Phys. Rev. D*, **48**, 1478.
 Bruenn S.W.: 1985, *Ap. J. Supl. Ser.*, **58**, 771.
 Canuto V. et al.: 1970, *Phys. Rev. D.*, **2**, 281.
 Cherepashchuk A.M.: 2003, *Physics Uspekchi*, **46**, 335.
 Chevalier R. A.: 2005, *Ap. J.*, **619**, 839.
 Chiu H.Y., Morrison P.: 1960, *Phys. Rev. Lett.*, **5**, 573.
 Chiu H.Y.: 1961, *Phys. Rev.*, **123**, 1040.
 Chiu H.Y., Salpeter E.E.: 1964, *Phys. Rev. Lett.*, **12**, 413.
 Chiu H.Y. Stabler R.C.: 1961, *Phys. Rev.*, **122**, 1317.
 Dicus D. A.: 1972, *Phys. Rev. D*, **6**, 941.
 Donati J.F. et al: 2002, *MNRAS*, **333**, 55.
 Donati J.F. et al.: 2001, *MNRAS*, **326**, 1265.
 Dutta S.T., Ratkovich S., Prakash M.: 2004, *Phys. Rev. D*, **69**, id. 023005.
 Eldridge J.J., Tout C.A.: 2004, *MNRAS*, **353**, 87.
 Fassio-Canuto L.: 1969, *Phys. Rev.*, **187**, 2141.
 Friman B.L., Maxwell O.V.: 1979, *Ap. J.*, **232**, 541.
 Ginzburg V.L., Ozernoy L.M.: 1964, *Zh. Exper. i Theor. Fiz.*, **47**, 1030.
 Goldreich P., Julian :1969, *Ap. J.*, **157**, 869.
 Hajakawa S.: 1978a, *Cosmic ray physics. Part 1. Nuclear aspects*, Mir, Moskva.
 Hajakawa S.: 1978b, *Cosmic ray physics. Part 2. Astrophysical aspects*, Mir, Moskva.
 Hansen C. J.: 1968, *Astrophys. Space Sci.*, **1**, 499.
 Heitel W.: 1954, *The quantum theory of radiation*, Oxford University Press, Oxford.
 Hubrig S. et al: 2013, *Astron. and Astrophys.*, **551**, id.A33, 13 pp.
 Itoh N. et al: 1989, *Ap. J.*, **339**, 354.
 Jordan S.: 2009, *Proc. IAU Symposium*, **259**, 369.
 Kepler S.O. et al.: 2013, *MNRAS*, **429**, 2934.
 Koers H.B.J., Wijers R.A.M.J.: 2005, *MNRAS*, **364**, 934.
 Kryvdyk V.: 1999, *MNRAS*, **309**, 593.
 Kryvdyk V.: 2001, *Adv. Space Res.*, **28**, 463.
 Kryvdyk V.: 2003, *Adv. Space Res.*, **31**, 1315.
 Kryvdyk V.: 2004, *Adv. Space Res.*, **33**, 484.
 Kryvdyk V.: 2010, *Kinem. Phys. Cel. Bodies*, **25**, 277.
 Landstreet J. D.: 1967, *Phys. Rev.*, **153**, 1372.
 Lattimer J.M. et al.: 1991, *Phys. Rev. Lett.*, **66**, 2701.
 Leng K.R.: 1974, *Astrophysical formulae*, Springer-Verlag, Berlin-Heidelberg-New York.
 Munakata H., Kohyama Y., Itoh N.: 1985, *Ap. J.*, **296**, 197.
 Petrosian G., Beaudet V., Salpeter E.E.: 1967, *Phys. Rev.*, **154**, 1445.
 Pontekorvo B.M.: 1959, *JETP*, **36**, 1615.
 Qian Y.Z., Woosley S.E.: 1996, *Ap. J.*, **471**, 331.
 Ratkovic S., Dutta S.I., Prakash M.: 2003, *Phys. Rev. D*, **67**, id. 123002.
 Reynoso M.M., Romero G.E., Sampayo O.A.: 2006, *Astron. Astrophys.*, **454**, 11.
 Ritus V. I.: 1961, *JETP*, **41**, 1285.
 Ruderman M.A., Sutherland: 1975, *Ap. J.*, **196**, 51.
 Sturrock P. A.: 1971, *Ap. J.*, **164**, 529.
 Tubbs D.L., Schramm D.N.: 1975, *Ap. J.*, **201**, 467.
 Wade G.A. et al.: 2014, *Proc. IAU Symp.*, **302**, 265.
 Woosley S.E., Heger A.: 2006, *Ap. J.*, **637**, 914.
 Zeldovich J.B., Novikov I.D.: 1971, *Theory of gravity and stellar evolution*. Nauka, Moscow (in Russian).