

SOLAR SYSTEM

DOI: <http://dx.doi.org/10.18524/1810-4215.2018.31.144550>

DOPPLER STATION FOR ORBITAL TRACKING OF LOW-ORBIT SPACECRAFTS BY THEIR RADIO BEACON SIGNALS

F. Bushuev, M. Kaliuzhnyi, M. Khalaley, V. Kryuchkovskiy, M. Kulichenko, O. Shulga

Research Institute "Mykolaiv Astronomical Observatory" (RI "MAO"),
Mykolaiv, Ukraine, dir@mao.nikolaev.ua

ABSTRACT. A ground station of orbital tracking of low-orbit spacecrafts has been developed and tested in the RI "Mykolaiv Astronomical Observatory". The station uses the Doppler shift of frequencies of signals radiated by spacecraft radio beacons for their orbital tracking. The station consists of: 1) 10-section antenna with a circular directional diagram and the operating frequency band 400-450 MHz, 2) electronic unit of connection of the antenna sections to a receiver, 3) the SDR-receiver used USB receiver of terrestrial digital TV and radio ("DVB-T+DAB+FM"), 4) personal computer. Software of the station includes the free program HSDR for SDR-receiver control, as well as an antenna direction control program, a program for determining a frequency of a signal, emitted by satellite radio beacon and received by the station, and a program for clarifying elements of satellite's orbit using the measured values of the frequency.

The NORAD ID of a satellite and a frequency of the signal emitted by its radio beacon should be set to clarify the satellite orbit. The antenna direction control program download current TLE (Two Line Elements) orbital elements of the satellite from the space-track.org site using the satellite's ID. These elements are used by the program to calculate, as functions of time, the values of range, azimuth and elevation angle of the satellite relative to the station. The program determines then the moments of the connections of the necessary antenna sections to the receiver, and performs these connections in the automatic mode, which provides continuous tracking of the satellite during its passage in the zone of direct radio visibility of the station. Simultaneous recording of the received radio signal is performed by the HSDR program in wav-files. The program of determining a frequency of satellite radio beacon signal analyzes the records and automatically detects the radio beacon signal and determines its frequency. The initial orbital elements obtained from the space-track site are clarified according to the measured values of the frequency using the program developed by V.A. Yamnitsky.

The report presents the results of the station test, which include an estimation of internal errors of the orbital elements determining of tracked satellites.

A network of stations similar to the one considered in the report could be used to orbital tracking of low-orbit spacecrafts equipped with radio beacons.

Keywords: Doppler's effect, radio beacon, low orbit spacecraft.

АБСТРАКТ. В НДІ «МАО» розроблена та протестована наземна станція орбітального супроводу низько орбітальних космічних апаратів. Для орбітального супроводу станція використовує доплерівський зсув частоти сигналів, які випромінюються радіомаяками космічних апаратів. До складу станції входить: 1) 10-секційна антена з круговою діаграмою спрямованості в діапазоні частот 400-450 МГц, 2) електронний блок підключення секцій антени до приймача, 3) SDR-приймач, створений з використанням USB-приймача наземного цифрового телебачення і радіо («DVB-T+DAB+FM»), 4) персональний комп'ютер. Програмне забезпечення станції включає безкоштовну програму HSDR управління SDR-приймачем, програму управління діаграмою спрямованості антени, програму визначення частоти сигналу, випроміненого радіомаяком супутника і прийнятого станцією, а також програму уточнення елементів орбіти супутника за вимірними значеннями частоти.

Для уточнення орбіти необхідно задати ідентифікатор NORAD супутника (ID) та частоту сигналу, випромінюваного його радіомаяком. Знаючи ID програма управління діаграмою спрямованості антени завантажує з сайту space-track.org поточні значення елементів орбіти супутника в TLE (Two-Line Elements) форматі. Отримані елементи орбіти використовуються програмою для обчислення змінювання у часі значень відстані до супутника, азимуту та кута місця супутника відносно станції та визначення моментів часу підключення необхідних секцій антени до приймача. Програма виконує ці підключення в автоматичному режимі, що забезпечує безперервний супровід супутника під час проходження ним зони прямої видимості станції. Одночасно програмою HSDR прийнятий радіосигнал записується в wav-файли. Програма визначення частоти сигналу супутникового радіомаяка аналізує записи, автоматично виявляє сигнал радіомаяка та визначає його частоту. За допомогою програми, розробленої В.А. Ямніцьким, початкові значення елементів орбіти супутника, отримані з сайту space-track.org, уточнюються за вимірними значеннями частоти.

В статті представлено результати тестування станції, які включають оцінку внутрішньої похибки визначення орбіти контрольованого супутника.

Мережа станцій, подібних розглянутих в статті, може бути використана для орбітального супроводу низько орбітальних супутників, обладнаних радіомаяками.

Ключові слова: Доплерівський ефект, радіомаяк, низькоорбітальний космічний корабель.

1. Introduction

The Doppler's effect is widely used for objects positioning in the past and today. For example, the Doppler systems Transit (in the USA), Tsikada and Parus (in the former USSR) were the first global navigation satellite systems in the world. The Transit system operated in 1967-1991 and its best accuracy was 20 m (Transit (satellite), 2018).

Another example is the Franco-American project ARGOS (ARGOS, 2018). It is a nowadays operating global satellite-based location and data collection system. The system is used to study and protect our planet's environment. Its purpose is locating any mobile objects (which named platforms) equipped with a compatible transmitter. The system uses the Doppler's effect on a transmission frequency ($401.650 \text{ MHz} \pm 30 \text{ kHz}$) to determine positions of the platforms. Herewith the exact value of a frequency transmitted by the platform is an unknown value and is determined together with platform coordinates. The system consist of six polar orbit satellites at an attitude of 859 km, nearly 60 ground receiving stations and two ARGOS processing centers (in the USA and France). The accuracy of the system is 250 m.

Well known also the French radar-based space surveillance system named GRAVES. It is an active Doppler radar which emits the CW (Continuous Wave) signal of 750 kW power at the frequency of 143050 kHz and has the range of 2000 km (Graves (system), 2018). There is a possibility to receive the GRAVES signal reflected by satellites and the Moon using relatively simple equipment even in Ukraine (Bushuev et al., 2013).

The Doppler station developed and tested in the RI "MAO" uses the passive radar principle and is intended to clarify orbits of low-orbit satellites by measuring the Doppler shift of frequencies of their radio beacons. Initial orbits of tracked satellites are taken from (SPACE-TRACK.ORG, 2018). The station uses a compact high-tech receiver of the megahertz frequency range that greatly simplifies and reduces the cost of its hardware.

2. Doppler station hardware and software

Block diagram of the station is shown in Fig. 1. As it follows from the figure, the station consists of the next equipment:

- 10-sections omnidirectional antenna in the upper hemisphere (S1, ..., S10);
- Antenna switches unit;
- Software defined radio (SDR) that includes personal computer (PC) and receiver used microchip Realtek RTL2832U as a demodulator of radio frequency signals (RF) of terrestrial digital television and radio "DVB-T+DAB+FM" (Digital Video Broadcasting-Terrestrial + Digital Audio Broadcasting + Frequency Modulation).

The height of the antenna is 9 m. Each its section is a Yagi-Uda antenna with horizontal polarization. The sections from S1 to S8 have eight (S1 and S5) or seven dipoles. The direction of these sections changes from the north (S1) to the east through 45 degrees. The sections S9 and S10 have only one dipole each and orthogonal directions: the north-south and east-west, respectively. These two sections are used for observations satellites which pass right over the station. The frequency band of the antenna is 430-440 MHz. The appearance of the antenna is shown in Fig. 2.

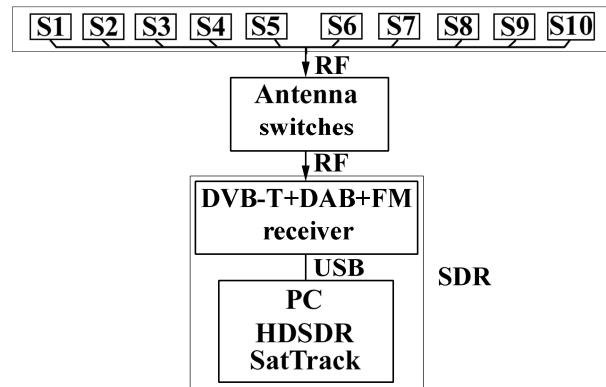

Figure 1: The block diagram of the station



Figure 2: The appearance of the antenna

The antenna switches unit has a microcontroller, transistor switches and reed relays that directly connect the desired antenna section to the receiver. Herewith the RS232 interface is used to exchange data with the PC. It is made on the FT232 chip that allows one to connect the unit to the PC via USB.

The "DVB-T+DAB+FM" receiver has the follow characteristics:

- 24-1766 MHz frequency band;
- 0.22 μV sensitivity;
- 50 dB dynamic range;
- using USB as an interface with the PC and as a power supply.

As the part of the SDR, the receiver provides analog-digital converting and transmitting to the PC the stream of 8-bit quadrature signals with sampling rate up to 3.2 MHz (GNSS-SDR, 2018).

Station software driven by Windows consists of:

- Drivers of the "DVB-T+DAB+FM" receiver with microchip RTL2832U;
- Freeware program HSDR (High Definition Software Defined Radio) is for control the receiver and for recording received signals into wav-files (HSDR, 2018);
- Program SatTrack is for calculating current position of a tracking satellite using its TLE (Two Line Elements) orbital elements from (SPACE-TRACK.ORG, 2018) and for automatically switching the antenna sections according to azimuth and elevation of the satellite;
- Program SatDoppler is for automatically detecting the satellite track on the plane "frequency-time" and determining function $F(t)$, where F – is a radio beacon frequency at a moment t ;

– Program WinMNK is for clarifying of TLE orbital elements using $F(t)$. The program has been developed by V.A.Yamnitsky (Kozelkov, 2012).

There are two stages to clarify orbit elements of the given satellite: real time and post processing. Next steps should be performed in real time:

- Setting the NORAD ID of the given satellite and start tracking the satellite using SatTrack for switching antenna sections;
- Setting (using HSDSR) the receiver’s frequency that corresponds to the satellite radio beacon frequency;
- Recording received signals in wav-files using HSDSR.

Post processing includes:

- Analyzing the wav-files and determining a function $F(t)$ using SatDoppler;
- Taking into account the measured function $F(t)$ clarifying of the satellite orbital elements using WinMNK.

3. Doppler station testing results

Figure 3 shows an HSDSR screenshot and illustrates satellites tracking. In order to improve the screenshot quality, its RGB colors were inverted and converted in grayscale. The screenshot contains so called "waterfall": amplitude distributions of spectral components of a signal received by the station during the given time interval.

On the "waterfall" the amplitude of the signal in the time-frequency domain is displayed using the brightness and color of the corresponding points of the domain - the marks. The "waterfall" shown on Fig. 3 is obtained during a passage of the OSCAR-19 satellite on 19 July 2018. As Fig. 3 shows, the signal duration is about 680 s and its frequency is in the range from 437118 kHz to 437099 kHz. The middle frequency of the given range is equal to $f_n = 437108.5$ kHz. Figure 3 also shows that f_n may be seen as an approximate estimation of a true radio beacon frequency f_0 . But the OSCAR-19 radio beacon has the frequency that is equal to $f_0 = 437125$ kHz (N2YO.COM, 2018). So, there is a difference between the frequency obtained HSDSR and the true radio beacon frequency which is equal to $(f_n - f_0) = -16.5$ kHz. This difference is due to the odds between the valid (f_v) and nominal (f_n) frequencies of a reference generator of the receiver. In this case, however, the ratio between f_v and f_n does not depend from frequency value and is

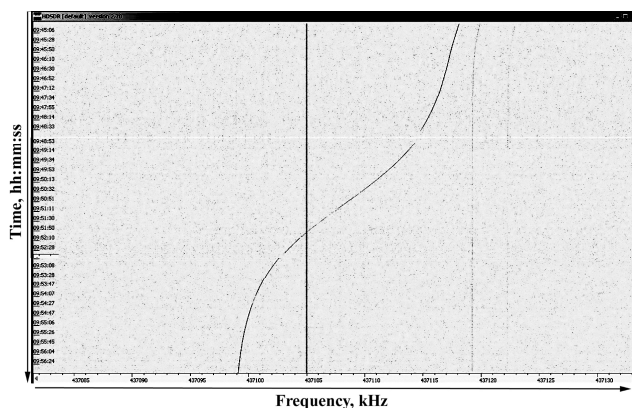

Figure 3: The HSDSR screenshot obtained during the OSCAR-19 passage on 19 July 2018.

determined for each receiver using a rubidium atomic reference generator. This ratio takes into account when the function $F(t)$ is determined.

Let $f_d = F(t) - f_0$ denote the frequency shift due to the Doppler effect. Let f_{dobs} denote the measured value of f_d and f_{dcalc} – the calculated value of f_d obtained using clarified orbital elements. The measured (v_{obs}) and calculated (v_{calc}) values of the radial component of the satellite velocity may be also obtained using the formula $v = -f_d \cdot c/f_0$, where c is speed of light.

Figure 4 illustrates the orbit determination results on the example of CUTE-1 tracked at 20 June 2017. Values of f_{dobs} (bold line) and f_{dcalc} (thin line) as a function of time are shown in Fig. 4(a). In Fig. 4(b) a distribution of residuals ($v_{obs} - v_{calc}$) are shown as the function of amplitude of the received signal. The data shown in Fig. 4(a) and (b) are obtained using the same observation of CUTE-1.

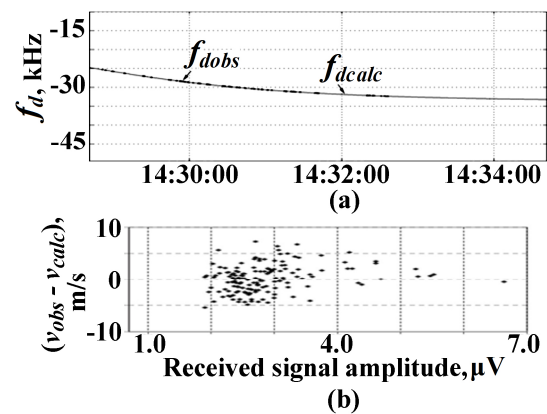

Figure 4: Orbit determination results on the example of CUTE-1 tracked at 20 June 2017.

Table 1: The main information about low-orbit satellites have been tracked by the station

Sat Name	NORAD ID	f_0 , MHz	Num Tracking
CUTE-1	27844	436.8375	9
CUTE-1.7	28941	437.382	2
KISEKI	33499	437.385	2
ITU-pSat1	35935	437.325	2
AAUSAT-4	41460	437.425	2
SwissCube-1	35932	437.505	1
PSat-A/B	40654	435.350	1
Somp	39134	437.503	1
Studsat1	35935	437.325	1
Techsat ^{*)}	42829	435.959	1
Oscar-19	20442	437.125	1

^{*)} The satellite has a laser ranging retroreflector.

The standard deviation of residuals ($f_{dobs} - f_{dcalc}$) for the f_{dobs} and f_{dcalc} values shown in Fig. 4(a) had been calculated and equal to 3.8 Hz. Figure 4(b) shows that there is a tendency of decreasing of absolute values of ($v_{obs} - v_{calc}$) when signal amplitude increasing.

Table 1 summarizes the main information about 11 low-orbit satellites tracked by the station up to now. The following information is in the table:

- Satellite's name (Sat Name);
- NORAD ID;
- Frequency of satellite radio beacon (f_0);
- Number of performed tracking of satellite (Num Tracking).

4. Conclusion

The ground station of orbital tracking of low-orbit spacecrafts has been developed and tested in the RI "MAO". The station uses the Doppler shift of frequencies of signals radiated by spacecraft radio beacons for their orbital elements determinations. Eleven satellites with radio beacons have been tracked now.

The following is proposed:

- Searching satellites with radio beacons based on Internet data and next checking by the Doppler station;
- Improvement station hardware and software to achieve full automation of the orbital tracking of satellites independent of radio signal spectrum;
- Comparison the Techsat orbit positions obtained by the station with corresponding the ILRS (International Laser Ranging Service) data.

Acknowledgements. Valeriy Aronovych Yamnitsky gone. Authors mourn the loss. Rest in peace, dear teacher and colleague.

References

- ARGOS. Products & Services. Advanced processing service, [online] Available at: <http://www.argos-system.org/> [Accessed 10 October 2018].
- Bushuev F.I., Vorsin G.V., Grinchenko A.A. et al.: 2013, in The Bulletin of the Ukrainian Centre of determination of the Earth Orientation Parameters, **5**, 48 (in Russian).
- GNSS-SDR operation with a Realtek RTL2832U USB dongle DVB-T receiver, [online] Available at: <http://gnss-sdr.org/node/50> [Accessed 10 October 2018].
- Graves (system), [online] Available at: [https://en.wikipedia.org/wiki/Graves_\(system\)](https://en.wikipedia.org/wiki/Graves_(system)) [Accessed 10 October 2018].
- HDSDR. High Definition Software Defined Radio, [online] Available at: <http://hdsdr.de/> [Accessed 10 October 2018].
- Kozelkov S.V., Makhonin E.I., Morgun A.A. et al.: 2012, Information Processing Systems, **2**, 42 (issue 3 (101)) (in Russian).
- N2YO.COM. Live Real Time Satellite Tracking and Predictions, [online] Available at: <http://www.n2yo.com> [Accessed 10 October 2018].
- SPACE-TRACK.ORG, [online] Available at: <https://www.space-track.org/auth/login> [Accessed 10 October 2018].
- Transit (satellite), [online] Available at: [https://en.wikipedia.org/wiki/Transit_\(satellite\)](https://en.wikipedia.org/wiki/Transit_(satellite)) [Accessed 10 October 2018].